

Technical Description Wheel Loader

L 544

Tipping load 10600 kg
Bucket capacity 3,0 – 6,0 m³
Operating weight 15,0 t
Engine output 121 kW/165 HP

**Liebherr
Norm Test**
2,6 l/100 t
11,4 l/h



LIEBHERR

The Better Machine.



Engine

Liebherr diesel engine	D 924 T-E A2 4-cylinder, inline engine, water-cooled exhaust-turbo charged	
Power output according to ISO 9249	121 kW (165 HP)	at 2000 RPM
Max. torque	690 Nm	at 1200 RPM
Displacement	6,64 litres	
Bore/stroke	122/142 mm	
Air cleaner	Dry type with main and safety element, pre-cleaner, service indicator on LCD display	
Operating voltage	24 V	
Battery	2 x 110 Ah/12 V	
Alternator	Three-phase AC, 28 V/55 A	
Starter motor	24 V/5,4 kW	



Travel gear

Hydrostatic travel transmission	All-wheel drive	
Design	Variable-displacement swashplate pump and axial piston motor in a closed-loop circuit with a 3-stage planetary transmission. Direction of travel is reversed by changing the flow-direction of the variable displacement pump	
Filtering system	Suction-side filter for the closed circuit	
Control	By travel and inching pedal The inching pedal makes it possible to control the tractive and thrust forces steplessly at full engine speed. The Liebherr joystick is used to control forward and reverse travel and select the travel stages	
Travel speeds	Stage 1	- 7,0 km/h
	Stage 2	- 16,5 km/h
	Stage 2A (automatic)	- 16,5 km/h
	Stage 3A (automatic)	- 38,0 km/h
	Forwards and in reverse with tyre size 23.5R25	



Axles

All-wheel drive	Fixed	
Front axle	Fixed	
Rear axle	Centre pivot, with 13° oscillating angle to each side. Obstacles up to 490 mm in height can be driven over (with all four wheels remaining in contact with the ground)	
Differentials	Automatic limited-slip differentials with 45% locking action in both axles	
Final drive	Planetary final drive in the wheel hubs	
Track width	2000 mm with all types of tyres	



Brakes

Wear-free service brake	Self-locking of the hydrostatic travel drive (acting on all four wheels) and additional pump-accumulator brake system with wet multi-disc brakes located in the wheel hubs. Two separate brake circuits	
Parking brake	Electro-hydraulically actuated spring-loaded brake system on the transmission	

The braking-system meets the requirements of the EC guidelines 91/320.



Tyres

Available sizes	23.5R25	
	20.5R25	
	Tubeless radial or cross-ply tyres on well-base rims	
Special tyres	By arrangement with the manufacturer	



Steering

Design	"Load-sensing" variable axial piston pump Central pivot with two double-acting, damped steering cylinders	
Angle of articulation	40° (to each side)	
Emergency steering	Electro-hydraulic emergency steering system	



Attachment hydraulics

Design	"Load-sensing" variable axial piston pump with output control and pressure cutoff	
Max. flow	230 l/min.	
Max. operating pressure	290 bar	
Cooling	Hydraulic oil cooling using thermostatically controlled fan and oil cooler	
Filtering	Return-line filter in the hydraulic reservoir	
Control	"Liebherr-Joystick" with hydraulic servo control	
Lift circuit	Lifting, neutral, lowering and float positions controlled by Liebherr joystick with detent; automatic lifting-limit circuit	
Tilt circuit	Tilt back, neutral, dump automatic bucket positioning	



Attachments

Geometry	Powerful Z-pattern linkage with tilt cylinder and cast steel cross-tube	
Bearings	sealed	
Arbeitsaktzeit bei Nennlast	Lifting	5,7 sec.
	Dumping	2,3 sec.
	Lowering (empty)	2,7 sec.



Operator's cab

Design	ROPS/FOPS cab resiliently mounted on rear section of vehicle and noise-damped; lockable door with sliding window and 180° opening angle; emergency exit; toughened safety glass windows, tinted; adjustable steering column as standard equipment; ROPS roll-over protection according to DIN/ISO 3471/EN 474-3 and FOPS falling objects protection according to DIN/ISO 3449/EN 474-1	
Operator's seat	6 way adjustable seat with seat belt, adjustable for operator's weight	
Cab heating and ventilation	With defrosting, fresh-air filter, air-recirculated-air mode and heater supplied from engine's cooling system. Air conditioning is standard equipment	



Noise emission

(86/662/EWG)	In the operator's cab	
	Without blower	69 dB(A)
	Max. blower output	73 dB(A)
	Outside cab	104 dB(A)





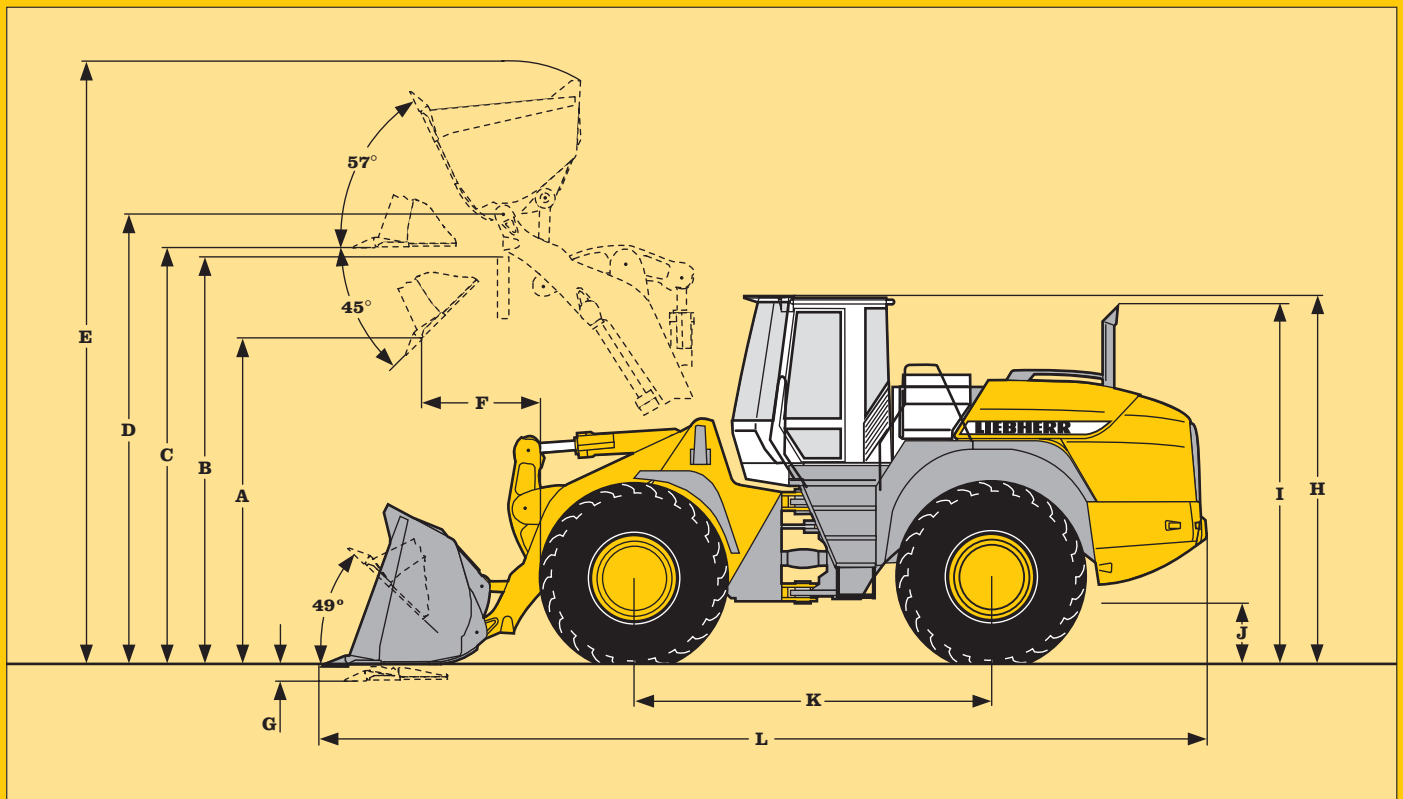

Capacities

Fuel tank	260 l
Engine oil (including filter change)	16 l
Pump distributor gears	2,5 l
Transmission	6 l
Front axle/wheel hubs	16,5/11 l
Rear axle/wheel hubs	16,5/11 l
Hydraulic tank	115 l
Hydraulic system, total	220 l

Technical Data



Bucket type	Cutting tools	Loading Bucket			
		T		T	
					
Bucket capacity	m ³	3,0		3,3	
Bucket width	mm	2700		2700	
Specific material weight	t/m ³	1,8	1,7	1,6	1,5
A Dumping height at max. lift height and 45° discharge	mm	2920	2760	2880	2760
B Dump-over height	mm	3500	3500	3500	3500
C Max. height of bucket bottom	mm	3645	3655	3645	3655
D Max. height of bucket pivot point	mm	3915			
E Max. operating height	mm	5350	5430	5395	5510
F Reach at max. lift height and 45° discharge	mm	1040	1225	1085	1225
G Digging depth	mm	85	70	85	70
H Height above cab	mm	3355			
I Height above exhaust	mm	3310			
J Ground clearance	mm	530			
K Wheelbase	mm	3150			
L Overall length	mm	7785	8030	7845	7950
Turning circle radius over outside bucket edge	mm	6235	6300	6250	6275
Lifting force (SAE)	kN	170	170	170	170
Breakout force (SAE)	kN	125	105	120	101
Tipping load, straight*	kg	12020	11070	11910	11030
Tipping load, articulated at 35°*	kg	10910	10060	10815	10020
Tipping load, articulated at 40°*	kg	10600	9760	10500	9720
Operating weight*	kg	15300	15630	15350	15670



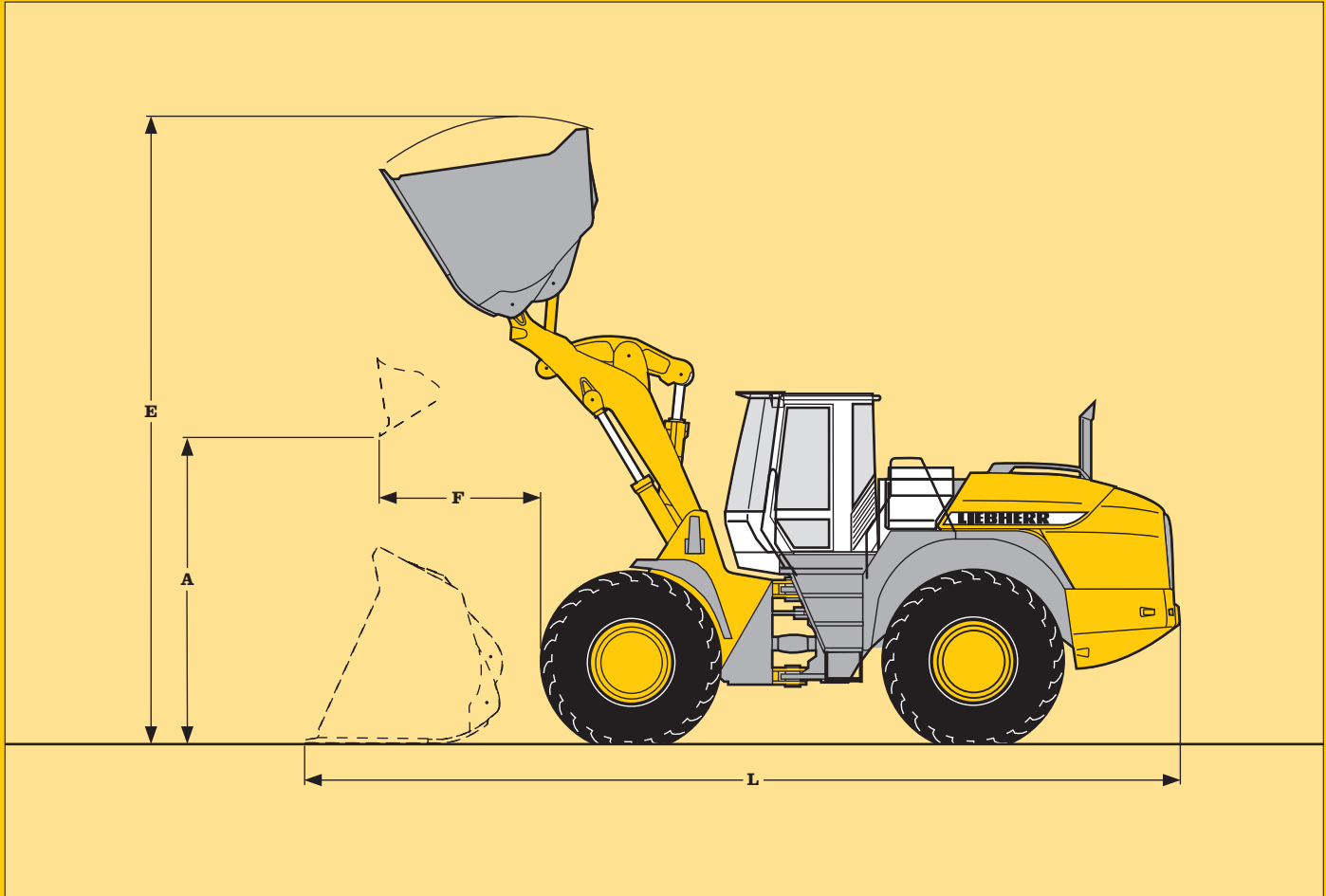

* The figures shown here are valid with Michelin XHA 23.5R25 tyres and include all lubricants, a full fuel tank, the ROPS/FOPS cab and the operator.
Different tyres and optional equipment will change the operating weight and tipping load.
T = Welded-on tooth holder with add-on teeth

Dimensions

Light material bucket



Light material bucket with bolt-on cutting edge

					
		5,0		6,0	
Bucket capacity	m ³	5,0		6,0	
Bucket width	mm	2950	2950	2950	2950
Specific material weight	t/m ³	0,8	0,7	0,6	0,5
A Dumping height at max. lift height	mm	2590	2490	2450	2360
E Max. operating height	mm	5585	5690	5785	5890
F Reach at maximum lift height	mm	1345	1505	1490	1640
L Overall length	mm	8050	8120	8170	8240
Tipping load, straight *	kg	10760	10360	10610	10250
Tipping load, articulated at 40° *	kg	9480	9150	9340	9020
Operating weight *	kg	15410	15780	15480	15890



* The figures shown here are valid with Michelin XHA 23.5R25 tyres and include all lubricants, a full fuel tank, the ROPS/FOPS cab and the operator.
Different tyres and optional equipment will change the operating weight and tipping load.

Attachments

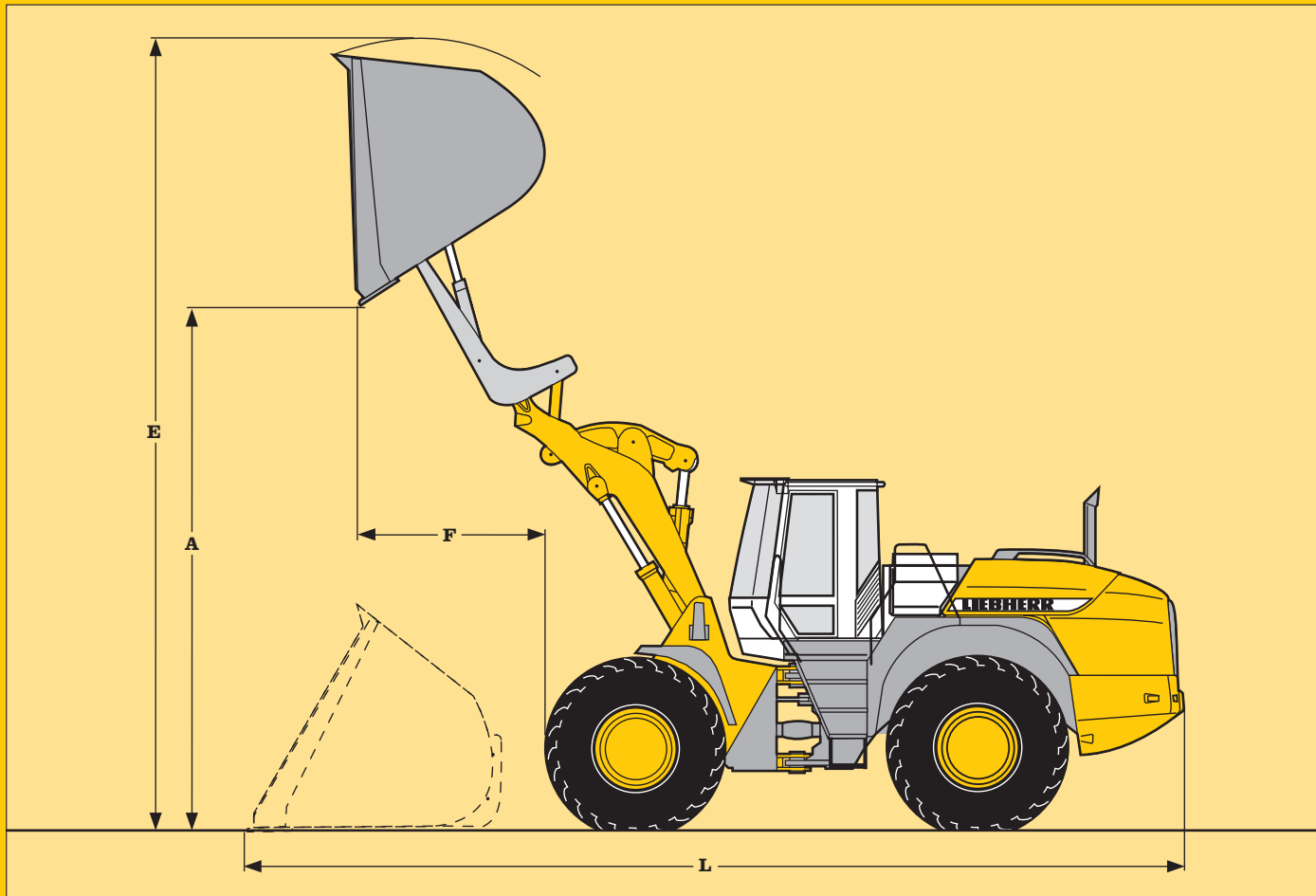
High-dump Bucket



High-dump bucket with bolt-on cutting edge

			
Bucket capacity	m ³	4,5	4,5
Bucket width	mm	2700	
Specific material weight	t/m ³	0,8	0,7
A Dumping height at max. lift height	mm	4600	4760
E Max. operating height	mm	6405	6565
F Reach at maximum lift height	mm	1730	1850
L Overall length	mm	8525	8730
Tipping load, straight*	kg	8930	8620
Tipping load, articulated at 40°*	kg	7850	7590
Operating weight*	kg	15420	15810

* The figures shown here are valid with Michelin XHA 23.5R25 tyres and include all lubricants, a full fuel tank, the ROPS/FOPS cab and the operator.
Different tyres and optional equipment will change the operating weight and tipping load.

Attachments

Fork carrier and fork

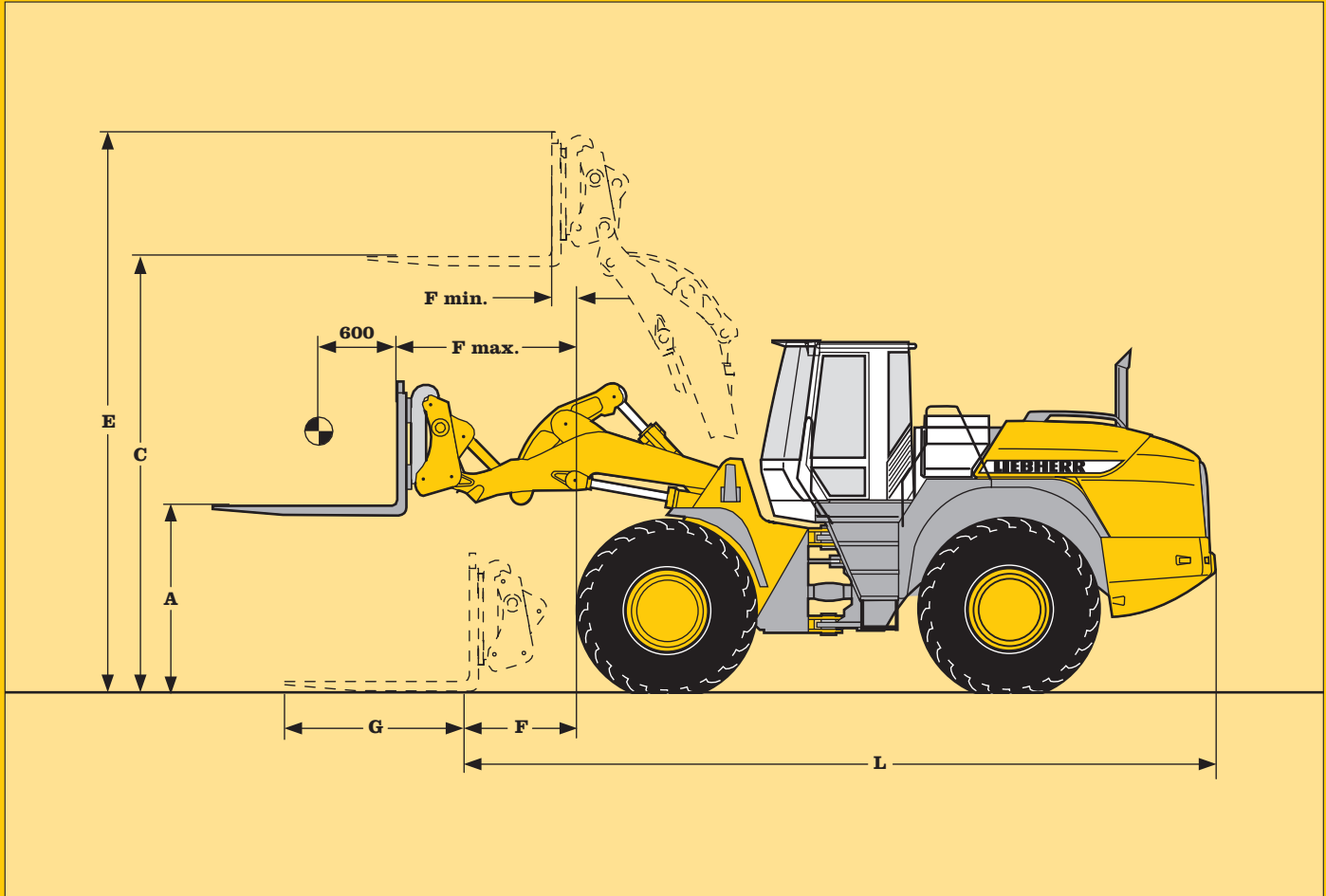

Fork carrier and fork

				
Fork carrier with quick change device			Fork carrier and fork FEM IV	
A	Lifting height at max. reach	mm	1780	1780
C	Max. lifting height	mm	3675	3675
E	Max. operating height	mm	4685	4685
F	Reach at loading position	mm	1020	1020
F max.	Max. reach	mm	1655	1655
F min.	Reach at max. lifting height	mm	835	835
G	Fork length	mm	1200	1500
L	Length - basic machine	mm	6885	6885
	Tipping load, straight *	kg	8280	8280
	Tipping load, articulated at 40°**	kg	7290	7250
	Operating weight*	kg	14930	14980

* The figures shown here are valid with Michelin XHA 23.5R25 tyres and include all lubricants, a full fuel tank, the ROPS/FOPS cab and the operator.
Different tyres and optional equipment will change the operating weight and tipping load.

** recommended payload (ISO 8313): for uneven ground = 60% of tipping load (articulated at 40°)
for smooth surfaces = 80% of tipping load (articulated at 40°)

Attachments

Selection of buckets

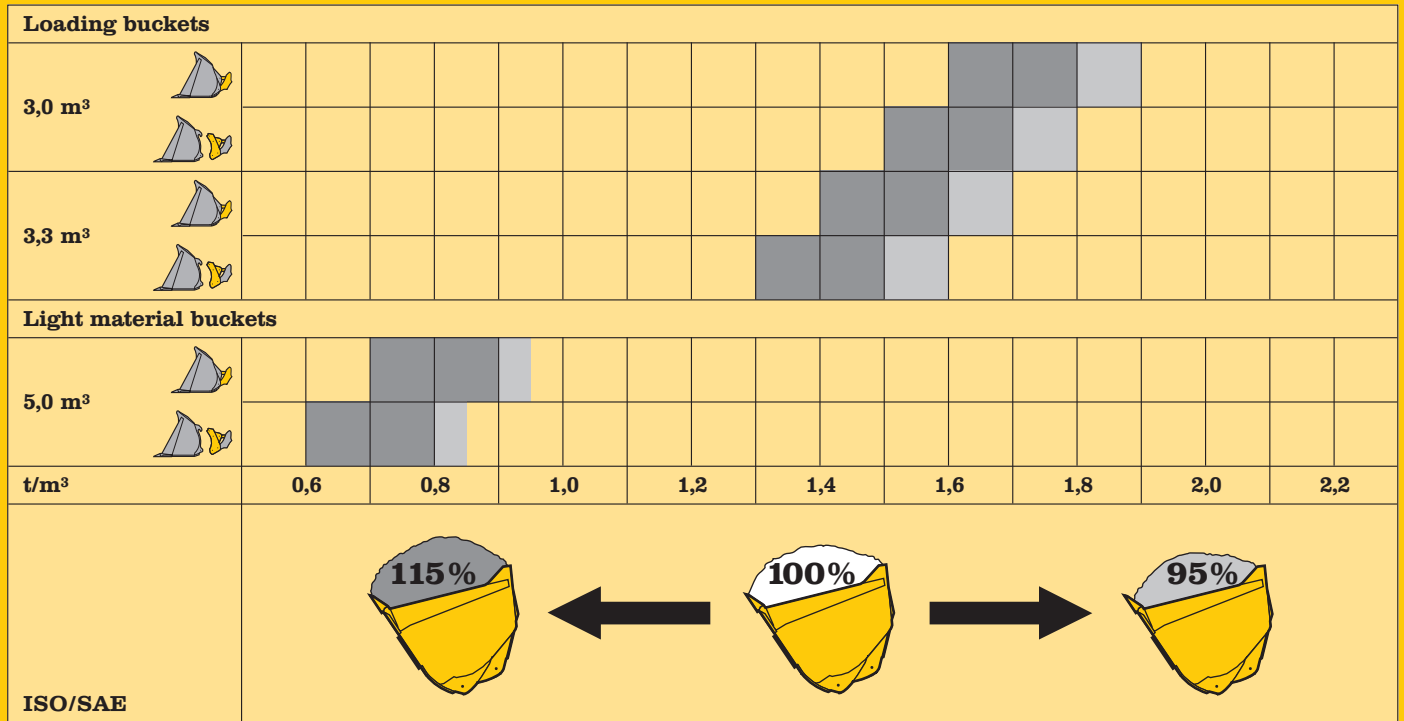

Bulk material densities (t/m³)

Gravel, moist _____ 1,9	Clay and gravel, dry _____ 1,4	Sandstone _____ 1,6
dry _____ 1,6	wet _____ 1,6	Slate _____ 1,75
wet, 6 – 50 mm _____ 2,0	Earth, dry _____ 1,3	Bauxite _____ 1,4
dry, 6 – 50 mm _____ 1,7	wet excavated _____ 1,6	Gypsum, broken _____ 1,8
crushed stone _____ 1,5	Topsoil _____ 1,1	Coke _____ 0,5
Sand, dry _____ 1,5	Weathered rock	Slag, broken _____ 1,8
moist _____ 1,8	50 % rock, 50 % earth _____ 1,7	Coal _____ 1,1
wet _____ 1,9	Basalt _____ 1,95	
Gravel and sand, dry _____ 1,7	Granite _____ 1,8	
wet _____ 2,0	Limestone, hard _____ 1,65	
Sand and clay _____ 1,6	soft _____ 1,55	
Clay, natural _____ 1,6		
dry _____ 1,4		
wet _____ 1,65		

Tyre sizes	Width over tyres mm	Change in vertical dimensions mm	Use
20.5R25 Dunlop T7LD	2560	- 20	Gravel
23.5R25 Dunlop T7LD	2625	+ 30	Gravel
23.5R25 Dunlop PG 120	2610	+ 50	Stone
20.5R25 Michelin XHA	2530	- 40	Gravel
23.5R25 Michelin XHA	2610	0	Gravel/Sand
625/70R25 Michelin XLD 70	2620	- 60	Gravel
20.5R25 Michelin X-MINE D2	2530	0	Stone/Scap material
20.5R25 Michelin XLD D2	2540	- 10	Stone/mining spoil
23.5R25 Good Year RL2+	2620	+ 30	Gravel
23.5R25 Good Year GP2B	2620	+ 30	Sand

Basic Machine

	Standard	Optional
Liebherr travel gear	●	
Ride control	●	
Liebherr shock absorbing element		X
Automatic travel mode	●	
20 km/h speed limiting		●
Electronical theft protection		●
Creep speed	●	
Electronic crowding force control	●	
Combined inching-braking system	●	
Multi-disc limited slip differentials in both axles	●	
Air cleaner system with pre-filter	●	
Particle protection for radiator		●
Emergency steering system	●	
Headlights	●	
Tail lights	●	
Working area lights at front	●	
Working area lights at rear	●	
Battery master switch	●	
Pre-heat system for cold starting	●	
Towing hitch	●	
Lockable doors, service flap an engine hood	●	
Toolbox with toolkit	●	
Dust filter system		●
Protective ventilation system		●
Amber beacon		●
Warning device for travel in reverse		X
Exhaust pipe - special steel	●	
Noise suppression package "101"		X
Automatic central lubrication system		●

Operator's cab

	Standard	Optional
Noise-damped ROPS/FOPS cab with tinted safety glass	●	
Hot-water heater with defroster and recirculated-air system	●	
Adjustable steering column	●	
Liebherr-joystick control	●	
Air conditioning system	●	
Liebherr operator's seat - adjustable in 6 ways	●	
Air sprung operator's seat with seat belt		●
Sliding window	●	
Emergency exit	●	
Floor mat	●	
Wash/wipe system for windscreen and rear window	●	
Interior rear-view mirror	●	
Sun visor	●	
Bottle holder	●	
Clothes hook	●	
Storage box	●	
Storage compartment	●	
Plug	●	
Ashtray	●	
Horn	●	
Provision for radio including Loudspeaker		●
Radio set		●
Operator's package	●	

Instruments and displays for:

	Standard	Optional
Diesel engine pre-heat	●	
Engine oil temperature	●	
Fuel reserve	●	
Timer for hours of operation	●	
Speedometer	●	
Travel speed ranges and gear selected	●	
Forward - reverse Travel	●	
Forward travel	●	
Reverse travel	●	
Speedometer	●	
Rev. counter	●	
Clock	●	

	Standard	Optional
Safety belt		X
Flashing turn indicators	●	
High-beam headlights	●	
Diagnosis system	●	

Warning lights for:

	Standard	Optional
Engine oil pressure	●	
Engine overheat	●	
Parking brake	●	
Hydraulic oil temperature	●	
Air cleaner blockage	●	
Battery charge	●	
Flow through emergency steering system	●	
Road travel		X

Audible warnings for:

	Standard	Optional
Engine oil pressure	●	
Engine overheat	●	
Overheat of hydraulic fluid	●	
Emergency steering system		X

Function keys for:

	Standard	Optional
Air conditioning	●	
Hazard warning flashers	●	
Parking brake	●	
Electronic tractive force adaptation	●	
Creep speed	●	
Ride control	●	
Automatic bucket positioner	●	
Hoist Kick-out	●	
Additional hydraulics	●	
Float position	●	
Headlights	●	
Working lights front	●	
Working lights rear	●	
Road travel	●	
Wash/wipe system for rear window	●	
Amber beacon	●	
Mode switch	●	

Rotary switches for:













	Standard	Optional
Blower	●	
Heater	●	
Fresh air or recirculated air	●	
Adjusting the crowding force counter	●	

Equipment

	Standard	Optional
Z-bar linkage	●	
Parallel linkage		X
Hydraulic servo control of working hydraulics	●	
Automatic bucket positioner - adjustable	●	
Automatic hoist kick out - adjustable	●	
Float position	●	
Loading buckets with and without teeth, or bolt-on cutting edge		●
High-dump bucket		●
Light material bucket		●
Fork carrier and lift forks		●
Hydraulic quick-change device		●
3rd hydraulic control circuit		●
3rd and 4th hydraulic control circuits		●
Comfort control		●
Country-specific versions		●

X = Not available

Liebherr wheel loaders - principal data.

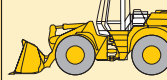
Tipping load: Bucket capacity: Operating weight: Engine output:	Stereoloader L 506  3215 0.8 4810 44/60	Stereoloader L 507  3465 0.9 4930 46/63	Stereoloader L 508  3895 1.0 5310 49/67	Stereoloader L 509  4440 1.1 5510 52/71	kg m ³ kg kW/hp
Tipping load: Bucket capacity: Operating weight: Engine output:	Stereoloader L 512  4615 1.3 7000 59/80	Stereoloader L 514  5305 1.5 7700 72/98			kg m ³ kg kW/hp
Tipping load: Bucket capacity: Operating weight: Engine output:	L 524  7005 2.0 10100 81/110	L 534  8625 2.4 12100 100/136	L 538  9000 2.5 12380 100/136	L 544  10600 3.0 15300 121/165	kg m ³ kg kW/hp
Tipping load: Bucket capacity: Operating weight: Engine output:	L 554  12270 3.5 17300 137/186	L 564  15285 4.0 22450 183/249	L 574  16690 4.5 24220 195/265	L 580  17850 5.0 24740 195/265	kg m ³ kg kW/hp

15/11/00

Environmental protection can help you earn money!

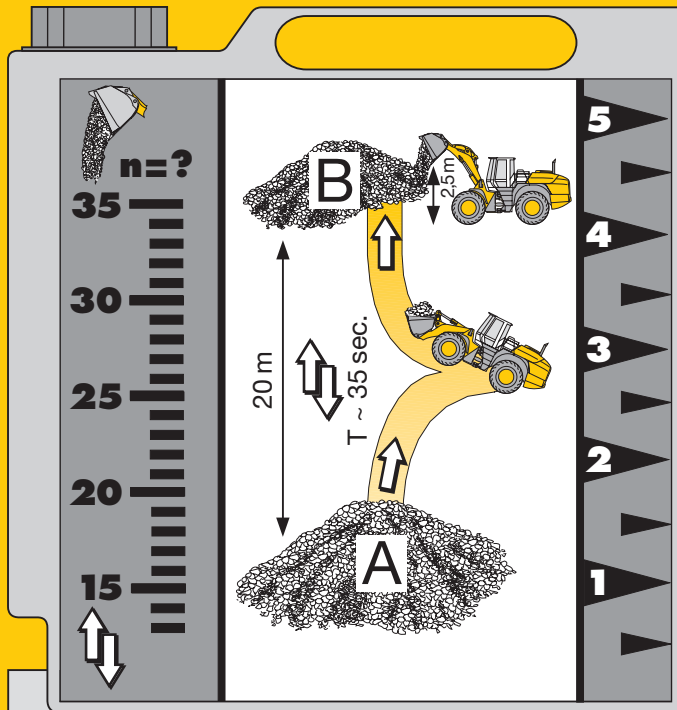

How economical is your wheel loader?

Measuring your wheeled loader's fuel consumption is as easy as this!

Liebherr test method.

Determine the number of working cycles that can be carried out with 5 litres of diesel fuel. The material is picked up from Heap A and carried in a Y movement to Point B, which is 20 m away. The height of the bucket when the material is dumped at Point B should be 2.5 m. These work cycles - each of which lasts for about 35 seconds - are continued until the 5 litres of fuel in the external tank have been used up.

How do you calculate the expected fuel consumption per working hour?

$$\frac{400}{\text{No. of working cycles}} = \text{fuel consumption per working hour}$$

Values for the Liebherr wheel loaders

	Numbers of working cycles	Litres/100 tons	Litres/hour
L 524: 2.0 m ³	n = 48	2.9	8.3
L 534: 2.4 m ³	n = 40	2.8	10.0
L 538: 2.5 m ³	n = 40	2.8	10.0
L 544: 3.0 m ³	n = 35	2.6	11.4
L 554: 3.5 m ³	n = 33	2.4	12.1
L 564: 4.0 m ³	n = 24	2.9	16.7
L 574: 4.5 m ³	n = 23	2.7	17.4
L 580: 5.0 m ³	n = 22	2.7	18.2

05/12/00

The Liebherr measuring canister set.

Any Liebherr dealer will supply you with the measuring device free of charge or conduct the standard test for you if requested.

**LIEBHERR-WERK BISCHOFSHOFEN GMBH, Postfach 49, A-5500 Bischofshofen, ☎ (06462) 888-0, Fax (06462) 888-385
www.liebherr.com, E-Mail: info@lbh.liebherr.com**

With compliments: